



APOLLO SERIES

THE RADIANT SPACE HEATER



 MADE IN BRITAIN

THE TANSUN APOLLO SERIES



INTRODUCING THE TANSUN APOLLO SERIES

Established over 30 years, Tansun Limited are world leading manufacturers of quartz full shortwave heating. Utilising our extensive experience and expertise when developing new products we create everything with the customer in mind.

It is well-known that some buildings such as warehouses, places of worship, gymnasiums, aircraft hangars, factories or similar are notoriously difficult to heat. They can have high ceilings, poor insulation and open doors or roller shutters. The Apollo series of heaters from Tansun Limited provides a revolutionary solution to heating these problem areas. Traditionally problematic areas take a long time to heat up,

then when doors or roller shutters are opened valuable heat escapes leaving workers feeling cold. The Apollo series has been a core product for Tansun for over 20 years, and for good reason, The high power options, along with the unique long lasting highly reflective aluminium reflectors, direct a focused energy beam to problem areas when installed at height. The characteristics of the Tansun full shortwave heating emitter provides high intensity radiant heat that other types of heating appliances cannot match. With over 30 models in its range the Tansun Apollo will provide a perfect heating solution whatever your requirement may be.



MAIN APPLICATIONS

Factories and Warehouses, Churches, Sports Halls, Aircraft Hangers, Universities and Education Centres, Shopping Centres and any large hard to heat buildings.

BENEFITS OF WORKING WITH TANSUN

- British manufactured
- Free heating design service
- Bespoke RAL colour options
- 30 Years experience in the industry
- Experienced after sales customer support
- Dedicated Research & Development Department
- Close contacts with all quality lamp manufacturers
- Constant development with leading lamp manufacturers
- Customised branding options for heaters
- Two year warranty
- Bespoke design service for specialised heating projects
- Constant innovation and new product releases
- Award winning products

APOLLO APPLICATION EXAMPLES

Below are examples of some of the main applications where the Apollo is often installed:

ZOOS AND ANIMAL ENCLOSURES



The Tansun Apollo provides instant clean heat with no fumes or harmful rays. This makes the Apollo perfect when installed into zoos and other types of animal enclosures. The Unique Apollo range offers pain relief, comfort and warmth and the ability to dry animals quickly. Also with no air circulation to stir dust the Apollo is perfect when installed into areas which may have hay etc.

PLACES OF WORSHIP



The Apollo is particularly popular for heating places of worship as they are often large cold buildings which are difficult to heat due to the intermittent nature of use. The Apollo can be switched on seconds before service with no pre-heating time required. Heaters can be mounted at high levels out of line of sight directed to the seated congregation below. Tansun understand the aesthetic consideration and importance of listed buildings.

FACTORIES AND WAREHOUSES



The Apollo is highly suitable for factory and warehouse environments as they can be installed in problem areas where operatives are working. This will provide spot heating which in turn dramatically reduces running costs of the building.

SPORTS HALLS & LEISURE CENTRES



Unlike other forms of heating the Apollo provides a perfect un-stuffed heating solution to sports halls and leisure facilities. The Apollo offers instant clean heat which keeps this environment fresh and comfortable when performing sporting activities.

AIRCRAFT HANGARS



These large difficult to heat areas benefit from the powerful Apollo series which can be mounted at high levels to project instant heat where required.

UNIVERSITIES EDUCATIONAL CENTRES AND EXHIBITION HALLS



The Apollo high powered models are popular when mounted at height (10+ metres). The Apollo is well suited to these types of environments as they provide an efficient blanket coverage of radiant heat that does not blow away.

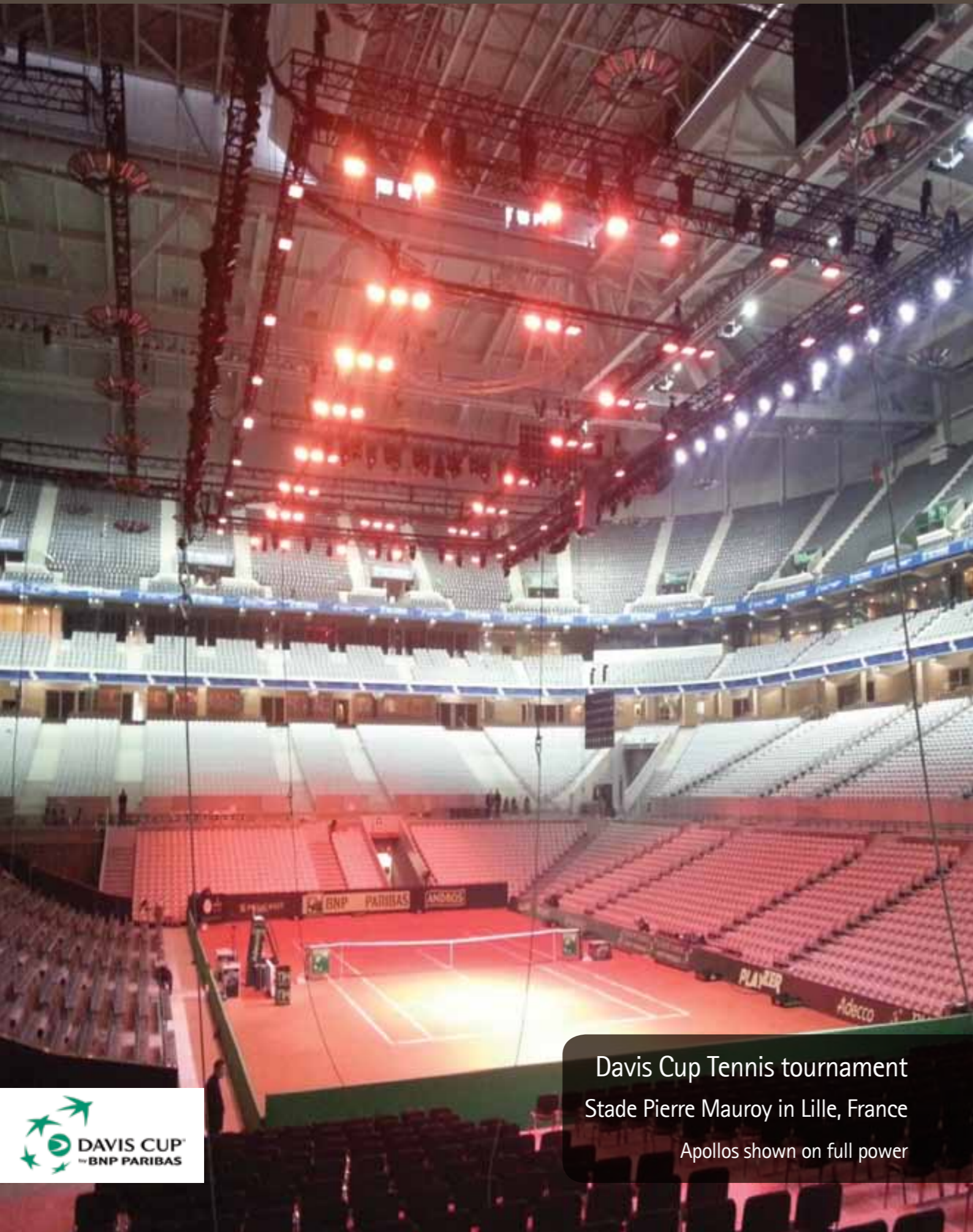

Davis Cup Tennis tournament
Stade Pierre Mauroy in Lille, France
Apollos shown on full power



TANSUN APOLLO FEATURES

Construction and design of the products

The Tansun Apollo range of high powered heaters have been designed and manufactured at the highest standard to provide radiant heat to commercial and industrial environments at high level. The Apollo boasts all of the performance benefits associated with full quartz shortwave technology while providing an economic solution for industrial and commercial heating requirements. It offers all the convenience of electricity together with very low running costs when compared to other forms of heating. The Tansun Apollo sells itself on its 'fit and forget' reputation which proves its reliability, durability and virtually maintenance free benefits.

Maximum performance features include

- Use of dedicated extruded aluminium profile. This helps the powerful heaters stay cool during running time. The aluminium profile is lightweight and eliminates rusting and discolouration.
- Unique designed integral aluminium heat sinks additionally help keep the heater cool and improve reliability compared with inferior alternatives on the market.
- Tansun full shortwave technology is noiseless and contributes to no atmospheric pollution and no movement of dust or other particles, which can be important in many environments.

- The unique deep, smooth parabolic reflectors produced using high grade anodised aluminium provides superior consistent reflectivity through 100% of the reflector. This provides intense uniformed heat coverage across a larger area. The 0.8mm thick reflector effortlessly projects heat forwards and in turn provides unbeatable heat performance.
- Apollo is hard wearing / durable, reliable and designed to stand hours of consistent commercial / industrial use. It has been engineered to dissipate heat in order to keep the body running cool which in turn increases life of the product and its components.
- The Apollo dedicated bracketry provide flexibility when installing on side walls or overhead. also the swivel bracket (selected models) offer directional heat where required which makes the Apollo an easy to install flexible heating solution.
- The Apollo is compatible with energy saving controllers which provides both controllability of heat output and energy saving benefits to all models including the three phase configuration which can be variably controlled.



BENEFITS OF TANSUN ELECTRIC HEATERS V GAS HEATERS

- Tansun electric radiant heaters are more energy efficient as they heat the objects, people and surfaces, which in turn radiate the heat back. With gas heaters, a proportion of the heat just dissipates as it is used to just heat the surrounding air.
- Smaller, which allows easier targeting positioning than gas heaters.
- Maintenance – Tansun heaters are virtually maintenance free. With an average lamp life of approximately 7000 hours the Apollo can be installed and forgotten about. Gas heaters must be maintained regularly such as having hoses and valves cleaned regularly to maintain performance. This adds extra cost and hassle.
- Tansun's radiant heaters are 96% energy efficient. Virtually all the energy used is converted directly into heat. There is no other form of heating that has a higher rate of conversion of energy to heat.
- Safer – no flammable gas bottles and no naked flame.
- No sensitivity to air movements, unlike gas where for example an open roller shutter door can negate hours of heating expense.
- No costly 'pre heating' time required. Tansun heaters will provide necessary heat within one second of switching on. Unlike with gas where you may need to wait for hours to feel the necessary results.
- Tansun Apollo has no moving parts and therefore will generally have a much longer and maintenance free lifespan than something like a gas heating system.
- Much more versatility and flexibility in terms of placement of heaters – for example Apollo can be wall mounted from fairly low to high levels, or even ceiling hug. Additionally no pipework required which further gives more flexibility of placement.
- Ability to control heat output more accurately with Tansun's range of energy saving controllers.



TANSUN RECESS APOLLO

The Recess Apollo range of heaters are designed to fit into commercial recessed areas to create a warm discreet heating solution indoors or outside.

Often wall space can be limited or unusable, The heaters can be strategically placed to 'spot heat' areas, targeting the heat only where required. The Recess Apollo is suitable for a range of applications including hotel reception areas, offices, train stations and factories to name just a few. The Recess Apollo can be fitted with dual ultra-low glare elements which are perfect when installed into commercial offices and public area environments.

Benefits of Tansun Ceiling Recess Apollo

- Provides a heating option where wall mounted heaters are not a viable option.
- Energy efficient – don't have to wait for several hours for room to reach desired temperature as with conventional heating.
- Little wastage – heat can be targeted where required.



- Large indoor areas can be heated in an efficient way and without air movement.
- The room and people within it are warmed directly in a similar way to the sun therefore the heat is not easily dissipated as is the case with most conventional HVAC systems where an open window, door or shutter can negate the effects of hours and hours of heating.
- Compatible with Tansun's range of energy saving controllers for further efficiency.
- Less clutter and simplified wall structures – no pipes and wires running along walls.
- No regular maintenance required.
- No dust movement – important in environments such as hospitals and laboratories.
- Long lamp life – approx. 7000hrs.
- Lamp can be replaced easily.
- Can retro fit an existing building / or work alongside conventional heating systems.



CASE STUDY

ST. MICHAEL'S CHURCH

St Michael's installed Tansun Apollos, to replace the old inefficient underfloor heating system. The underfloor heating had to be switched on three days before Sunday service, which lasted only a few hours. This was proving to be very costly, and unsustainable for the Church. They needed a solution and contacted Tansun.

Tansun surveyed the building and with our specialist trained staff carefully designed a heating scheme taking into account all the various important factors which included aesthetic consideration, power availability and where the heaters would be best situated based on the requirements and needs of the church.

St Michael's decided to go ahead with Tansun's proposal, installing the heaters during the warmer summer months so they could benefit from the system in time for the winter. The installation was clean from any major building works and avoided any disruption to the church activities.

The results from the changeover to Tansun were self-evident. They now have only to turn the heaters on exactly when the heat is required with zero 'pre heating' time required. This has enabled the church to save a staggering 75% per annum



on their heating bills. In the September to March period, they spent an average of £4,500 using the old inefficient heating system. For the same period using the Tansun Apollo models this cost came down to below £1000.

As a result, St Michael's were delighted with the results. Father Stephen Squires said 'We have tried for years to come up with an effective heating solution for the church, and eventually we found Tansun which is the only system that worked for the church. The Tansun Apollo has been going strong for over 25 years, and the above results are far from isolated. Time and time again the Apollo has delivered results where other conventional heating systems have failed.

CHURCH HEATING COSTS:

The figures below show the heating costs for the church for the exact same period for the before and after installing the Tansun Apollo's. All the figures are data provided by St. Michael's Church themselves.

Sept 2010 – March 2011 (Old heating system)	Sept 2011 – March 2012 (Tansun system installed)
Sept: £29.95	Sept: £6.49
Oct: £388.36	Oct: £44.00
Nov: 168.17	Nov: £92.67
Dec: £1546.15	Dec: £254.77
Jan: £404.69	Jan: £243.23
Feb: £1050.43	Feb: £153.27
Mar: £707.81	Mar: £95.33
Total £4,295.56	Total: £889.76

The figures show the church is now making a saving of 79% per annum on heating costs during the main months when the heating is required.

"We have tried for years, literally years to find an effective heating solution for this church and the Tansun heating system is the only one we have found that provides an effective heating solution whilst dramatically reducing our heating costs. We are now saving over 75% per annum on heating costs."

Parish priest 'Rev Fr Stephen Squires'





TANSUN CASE STUDY

Tansun manufacture all our products at our factory headquarters in West Bromwich, England. The factory area is approximately 60,000 square feet. When Tansun purchased the building the factory area was heated via a gas fired warm air system.

This old system was over 500kw in power and needed to be switched on approximately two hours before the factory operatives arrived in the winter months, to bring the room up to the required ambient temperature

The system was also unnecessarily heating the whole factory area and was obviously very costly to run. The factory has three large roller shutter doors and when opened the majority of the heat would escape and cold air would rush into the factory areas. In the colder months the heating had to be kept running 24 hours a day to combat this 'wasted heat' situation.

Recognising this problem Tansun replaced the old inefficient gas system with a number of Tansun Apollo heater configurations. Correct power options were situated in areas where operatives were working a spot heating scenario was created. The heaters were strategically placed to avoid the need to heat the entire factory building.

Main benefits of replacing the old gas system with the Apollos full shortwave heaters.

- Replaced the old 500 kW+ gas heating system with Apollos which only needed 72kW.
- No pre heating time now required to bring the area up to the ambient temperature required.
- The Apollos can be controlled up or down to the exact level required.
- Zonal spot heating in dedicated areas of the factory. No wasted energy heating the whole factory.
- There are now zero ongoing maintenance costs, unlike old gas system had to be maintained and serviced regularly adding to costs.
- Tansun are saving over 50% on heating costs during the winter months compared with the old gas system.
- The roller shutter doors can be opened without affecting the heat performance
- There is no dust and air movement providing a healthier, and safer work environment.

The Tansun factory is a typical example of the benefits for factory / warehouse environments when installing the Tansun Apollo.



TANSUN SERVICES WE OFFER

Tansun have been manufacturing and selling the Apollo successfully for over 25 years. We offer various individual services to meet the requirements of each distinct installation.

BESPOKE

Tansun constantly work alongside architects, specifiers and engineers who require bespoke heating systems for specialist heating applications. If necessary Tansun can produce bespoke solutions in various ways to meet your custom requirements. such as design and manufacture of frames and brackets to suit a particular environment or project. For example the photo opposite is from a custom designed 'chandelier' created around the Apollo for a particular church in France and was based on a design brief and requirement of the church.



GUARDS

The Apollos are available with or without guards to suit particular needs. Often when the Apollos are mounted high up guards are not required or specified, however when mounted lower down the guard may be required. Mainly used in sports halls and leisure centres.



RAL COLOUR OPTIONS

Tansun can create the Apollos in most RAL colour options. As we are a UK based manufacturer this allows us to have the flexibility to produce heaters in colour variants to suit. This simple feature can be important for the specification sector to help blend in with particular environments and colour schemes.



ULTRA DUAL LOW GLARE

The Tansun Apollo heaters have the benefit of installing dual ultra-low glare technology. This feature provides high powered heaters to be less obtrusive in areas that do not require any extra light such as theatres, media production areas and places of worship. The heaters are fitted with unique reducing glare gold reflectors and fitted with low glare elements that reduces light output by up to 80%.



FREE HEATING DESIGN SERVICE

Tansun offer a free individual heating design service. If you send us the necessary information on the proposed scheme we will create a proposed layout for the heaters based on the particular building and environment, taking into account all the permutations we are informed about. If necessary we can come out to do a site visit to assess the scheme further.



APOLLO CONTROLLABILITY

REMOTE

RECEIVER



The Apollo is compatible with a range of energy saving controllers to further enhance efficiency. Tansun's controllers allow the heaters to be turned on/off and dimmed down from 100% to 75% to 50%. Higher powered controllers are available for larger models.



APOLLO INSTALLATIONS

Below are some of the installations Tansun have been successful in achieving varying over a wide range of projects.

Heathrow

The Apollo was specified and installed at the new Terminal 5 baggage area for London's Heathrow airport.



Tansun Apollo has been used by NATO and the Ministry of Defence for rapid deployment forces.



The Apollo was specified in the control point area in London Tower Bridge.



TATE & LYLE

The Apollo was specified in the warehouse for Tate and Lyle – one of the world's leading sugar manufacturers.



SAN GIORGIO CHURCH MOLTENO

Tansun heaters are installed at the historic church San Giorgio in the Lombardia area in northern Italy.



Tansun Apollos are installed at the Stade Pierre Mauroy in Lille, France for the world renowned 'Davis Cup' tennis tournament.



COVERAGE DIAGRAM FOR TANSUN APOLLO HEATERS HORIZONTAL
ANGLE MOUNTED AT 45° ON A WALL OR CHAIN HUNG MODE

MODEL	'A' MOUNTING HEIGHT (m)	'B' DEPTH (m)	'C' WIDTH AT REAR (m)	'D' WIDTH AT FRONT (m)	CALCULATED COVERAGE AREA (m SQ)
A	2.0	2.9	2.7	4.9	11.2
A	2.5	3.6	3.3	6.0	16.7
A	3.0	4.2	3.9	7.1	23.3
B	2.5	3.8	3.3	6.2	18.3
B	3.0	4.4	3.9	7.3	24.7
B	3.5	4.5	4.5	8.4	29.0
C	3.0	4.0	4.0	7.3	22.9
C	3.5	4.6	4.6	8.4	30.0
C	4.0	5.2	5.2	9.5	38.0
C	4.5	5.7	5.8	10.6	47.0
J	2.5	3.6	5.1	9.1	25.5
J	3.0	4.2	6.0	10.7	35.3
J	3.5	4.9	6.9	12.3	46.8
K	3.0	4.2	5.5	9.5	31.7
K	3.5	4.9	6.3	10.8	41.6
K	4.0	5.5	7.0	12.1	52.9
K	4.5	6.2	7.7	13.5	65.5
E	4.5	6.0	6.0	11.0	51.3
E	5.0	6.1	6.6	11.6	55.1
E	6.0	7.1	7.8	13.6	76.0
E	7.0	8.2	8.9	15.6	100.3
E	8.0	9.2	10.1	17.6	127.9
F	5.0	6.1	7.0	12.0	57.7
F	6.0	7.1	8.2	14.0	79.0
F	7.0	8.2	9.4	16.0	103.8
F	8.0	9.2	10.5	18.1	131.8
L	3.5	4.2	6.3	9.7	33.5
L	4.5	5.3	7.0	12.3	50.7
L	5.0	5.8	7.4	13.6	60.7
L	6.0	6.8	8.2	16.3	83.5
L	7.0	7.9	9.4	18.9	111.4
L	8.0	8.9	10.5	21.6	143.2

COVERAGE DIAGRAM FOR TANSUN APOLLO HEATERS IN A FACE HORIZONTAL CEILING HUNG MODE

MODEL	'A' MOUNTING HEIGHT (m)	'B' WIDTH (m)	'C' LENGTH (m)	CALCULATED COVERAGE AREA (m SQ)
A	2.0	1.3	3.5	4.5
A	2.5	1.6	4.3	6.8
A	3.0	1.9	5.1	9.6
B	2.5	2.1	3.2	6.9
B	3.0	2.5	3.8	9.6
B	3.5	2.9	4.4	12.8
C	3.0	2.6	3.8	10.1
C	3.5	3.0	4.4	13.4
C	4.0	3.4	5.0	17.0
C	4.5	3.8	5.6	21.1
J	2.5	1.6	4.7	7.5
J	3.0	1.9	5.5	10.5
J	3.5	2.2	6.3	13.8
K	3.0	1.9	5.9	11.3
K	3.5	2.2	6.7	14.8
K	4.0	2.5	7.5	18.8
K	4.5	2.8	8.3	23.2
E	4.5	4.2	6.0	24.8
E	5.0	4.6	6.5	29.8
E	6.0	5.4	7.7	41.4
E	7.0	6.2	8.8	54.7
E	8.0	7.0	10.0	70.0
F	5.0	4.6	7.0	31.8
F	6.0	5.4	8.1	43.6
F	7.0	6.2	9.3	57.4
F	8.0	7.0	10.4	73.0
L	3.5	2.4	6.7	16.0
L	4.5	3.0	8.3	24.8
L	5.0	3.3	9.1	29.8
L	6.0	3.9	10.7	41.4
L	7.0	4.5	12.2	54.8
L	8.0	5.1	13.8	70.2

HEAT COVERAGE AREAS

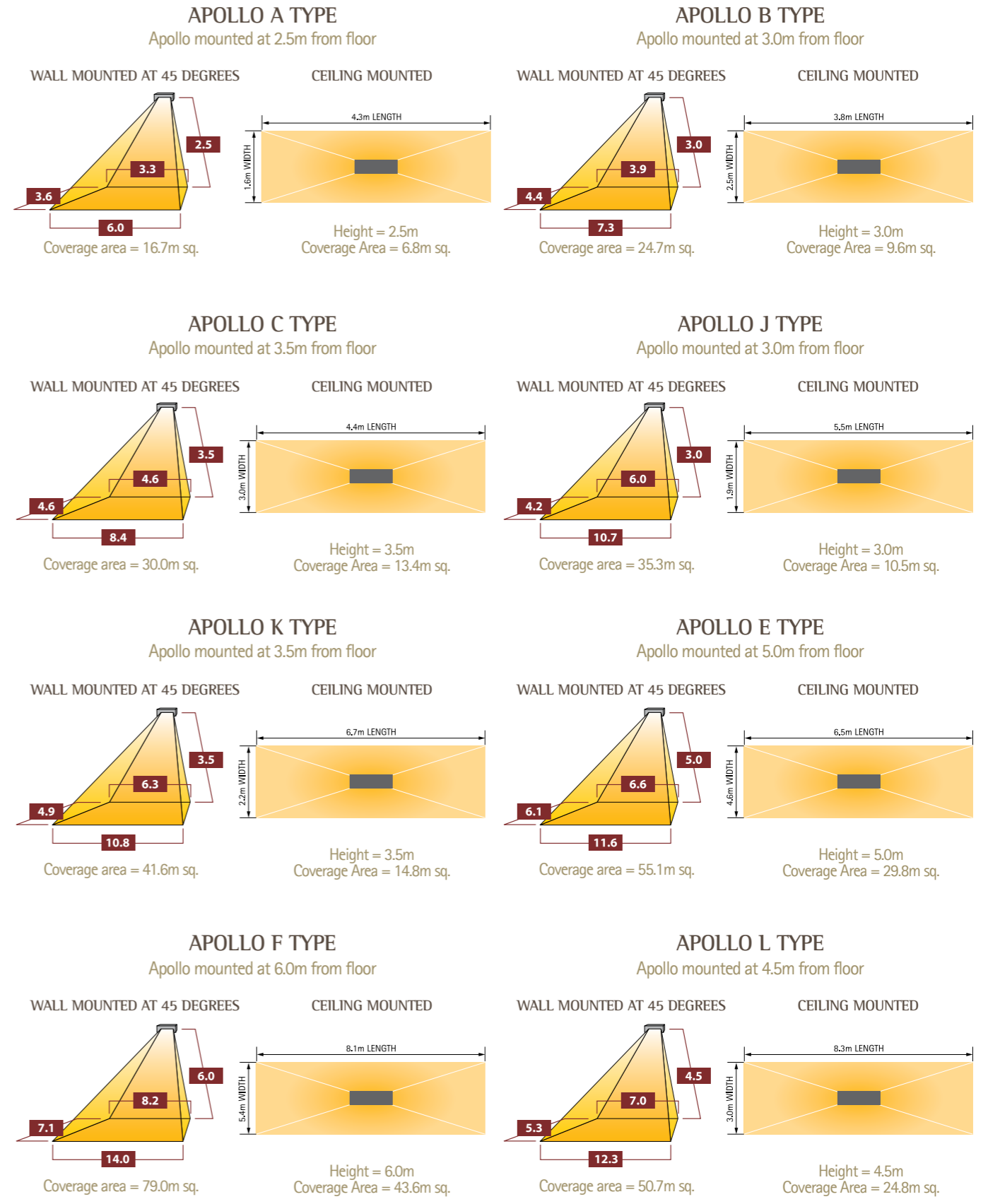

Above values should be used a guide only

APOLLO SPECIFICATION TABLE

Model	Voltage (V)	Lamps x power (kW)	Total power (kW)	Phase supply (V)	Current per phase (A)	Minimum height from floor	Minimum distance from ceiling	Minimum distance from side wall	Body dimensions (W x H x D) (mm)	Weight without guard
A1A2 10IP	230	1 x 1.0	1.0	1	4.3	2.0m	0.15m	1.0m	422 x 255 x 110	3.0kg
A1A2 15IP	230	1 x 1.5	1.5	1	6.5	2.0m	0.15m	1.0m	422 x 255 x 110	3.0kg
A1A2 20IP	230	1 x 2.0	2.0	1	8.7	2.0m	0.15m	1.0m	422 x 255 x 110	3.0kg
A1B2 20IP	230	2 x 1.0	2.0	1	8.7	2.0m	0.5m	1.5m	422 x 390 x 110	4.0kg
A1B2 30IP	230	2 x 1.5	3.0	1	13.0	2.0m	0.5m	1.5m	422 x 390 x 110	4.0kg
A1B2 40IP	230	2 x 2.0	4.0	1	17.4	2.5m	0.5m	1.5m	422 x 390 x 110	4.0kg
A1C2 30IP	230	3 x 1.0	3.0	1	13.0	2.0m	0.5m	1.5m	422 x 525 x 110	5.0kg
A1C2 45IP	230	3 x 1.5	4.5	1	19.6	2.5m	0.5m	1.5m	422 x 525 x 110	5.0kg
A1C2 60IP	230	3 x 2.0	6.0	1	26.0	3.0m	0.5m	1.5m	422 x 525 x 110	5.0kg
A1J2 20IP	230	2 x 1.0	2.0	1	8.7	2.5m	0.15m	1.0m	857 x 255 x 110	6.0kg
A1J2 30IP	230	2 x 1.5	3.0	1	13.0	2.5m	0.15m	1.0m	857 x 255 x 110	6.0kg
A1J2 40IP	230	2 x 2.0	4.0	1	17.4	2.5m	0.15m	1.0m	857 x 255 x 110	6.0kg
A1K2 30IP	230	3 x 1.0	3.0	1	13.0	2.5m	0.15m	1.5m	1282 x 255 x 110	8.0kg
A1K2 45IP	230	3 x 1.5	4.5	1	19.6	2.5m	0.15m	1.5m	1282 x 255 x 110	8.0kg
A1K2 60IP	230	3 x 2.0	6.0	1	26.0	3.0m	0.15m	1.5m	1282 x 255 x 110	8.0kg
A3C2 30IP	400	3 x 1.0	3.0	3*	4.3	2.0m	0.5m	1.5m	422 x 525 x 110	5.5kg
A3C2 45IP	400	3 x 1.5	4.5	3*	6.5	2.5m	0.5m	1.5m	422 x 525 x 110	5.5kg
A3C2 60IP	400	3 x 2.0	6.0	3*	8.7	3.0m	0.5m	1.5m	422 x 525 x 110	5.5kg
A3E2 60IP	400	6 x 1.0	6.0	3*	8.7	3.0m	0.5m	1.5m	857 x 630 x 110	12.0kg
A3E2 90IP	400	6 x 1.5	9.0	3*	13.0	4.0m	0.5m	1.5m	857 x 630 x 110	12.0kg
A3E2 120IP	400	6 x 2.0	12.0	3*	17.4	4.5m	0.5m	1.5m	857 x 630 x 110	12.0kg
A3F2 90IP	400	9 x 1.0	9.0	3*	13.0	4.0m	0.5m	1.5m	1282 x 630 x 110	20.0kg
A3F2 135IP	400	9 x 1.5	13.5	3*	19.6	5.0m	0.5m	1.5m	1282 x 630 x 110	20.0kg
A3F2 180IP	400	9 x 2.0	18.0	3*	26.1	6.0m	0.5m	1.5m	1282 x 630 x 110	20.0kg
A3K2 30IP	400	3 x 1.0	3.0	3*	4.3	2.5m	0.5m	1.5m	1282 x 255 x 110	8.0kg
A3K2 45IP	400	3 x 1.5	4.5	3*	6.5	2.5m	0.5m	1.5m	1282 x 255 x 110	8.0kg
A3K2 60IP	400	3 x 2.0	6.0	3*	8.7	3.0m	0.5m	1.5m	1282 x 255 x 110	8.0kg
A3L2 60IP	400	6 x 1.0	6.0	3*	8.7	3.0m	0.5m	1.5m	1282 x 441 x 110	17.0kg
A3L2 90IP	400	6 x 1.5	9.0	3*	13.0	4.0m	0.5m	1.5m	1282 x 441 x 110	17.0kg
A3L2 120IP	400	6 x 2.0	12.0	3*	17.4	4.5m	0.5m	1.5m	1282 x 441 x 110	17.0kg

* Star connection with neutral star point to balance load.

TANSUN APOLLO A1A2 - 10IP/15IP/20IP



Apollo mounted at 2.5m from floor

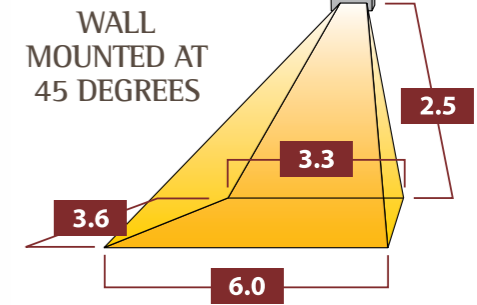

Coverage area = 16.7m sq.

CEILING MOUNTED

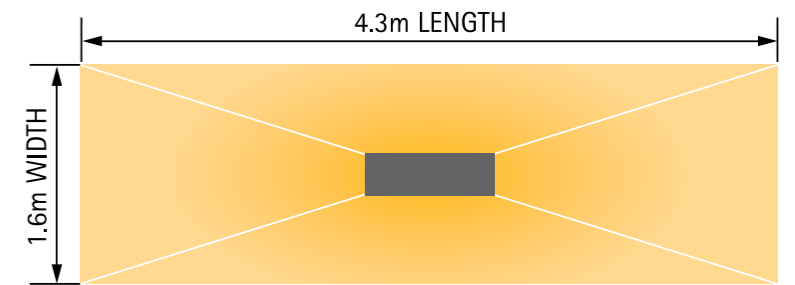

Height = 2.5m. Coverage Area = 6.8m sq.

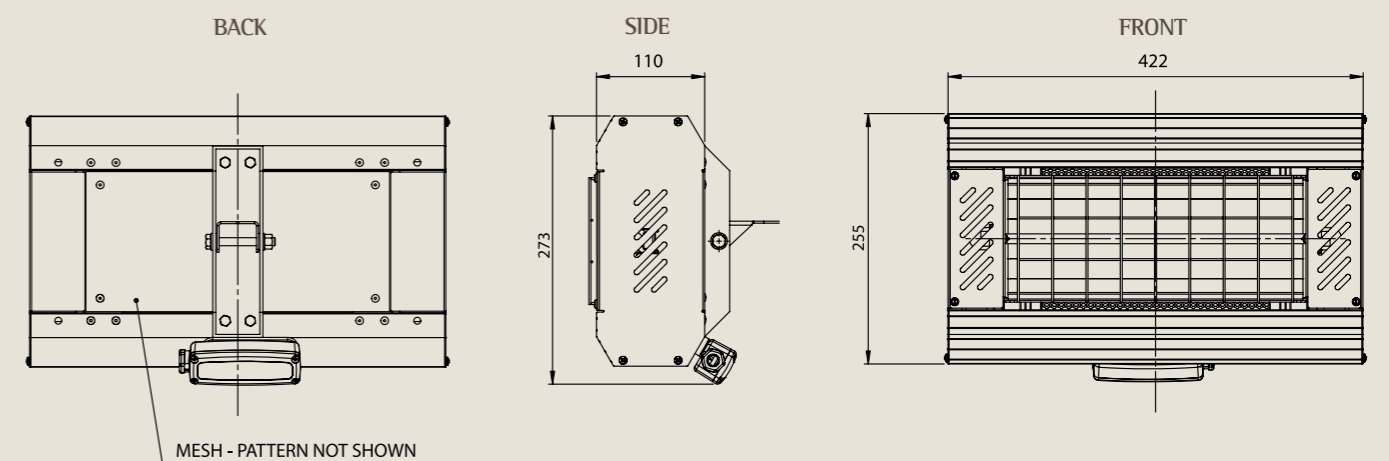

Model	Voltage (V)	Lamps x power (kW)	Total power (kW)	Phase supply (V)	Current per phase (A)	Minimum height from floor	Minimum distance from ceiling	Minimum distance from side wall	Body dimensions (W x H x D) (mm)	Weight without guard
A1A2 10IP	230	1 x 1.0	1.0	1	4.3	2.0m	0.15m	1.0m	422 x 255 x 110	3.0kg
A1A2 15IP	230	1 x 1.5	1.5	1	6.5	2.0m	0.15m	1.0m	422 x 255 x 110	3.0kg
A1A2 20IP	230	1 x 2.0	2.0	1	8.7	2.0m	0.15m	1.0m	422 x 255 x 110	3.0kg

TANSUN APOLLO A1B2 - 20IP/30IP/40IP



Apollo mounted at 3.0m from floor

WALL MOUNTED AT 45 DEGREES

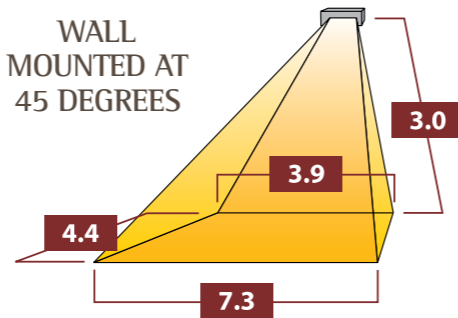

Coverage area = 24.7m sq.

CEILING MOUNTED

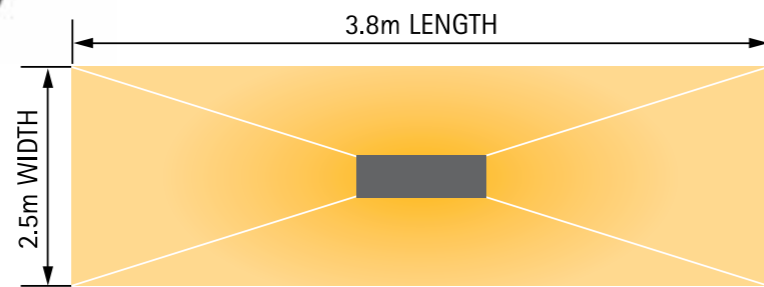

Height = 3.0m. Coverage Area = 9.6m sq.

TANSUN APOLLO A1C2 - 30IP/45IP/60IP



Apollo mounted at 3.5m from floor

WALL MOUNTED AT 45 DEGREES

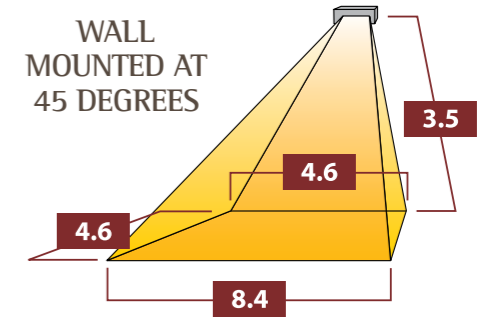

Coverage area = 30.0m sq.

CEILING MOUNTED

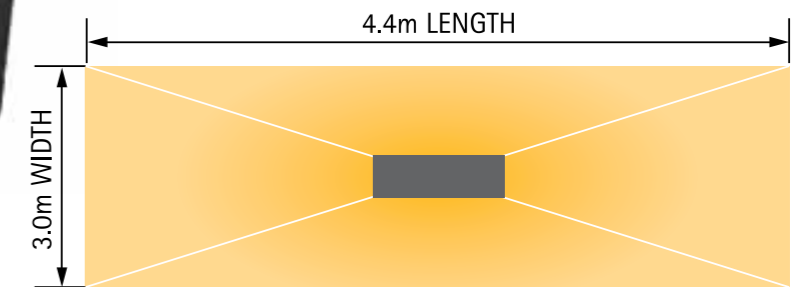

Height = 3.5m. Coverage Area = 13.4m sq.

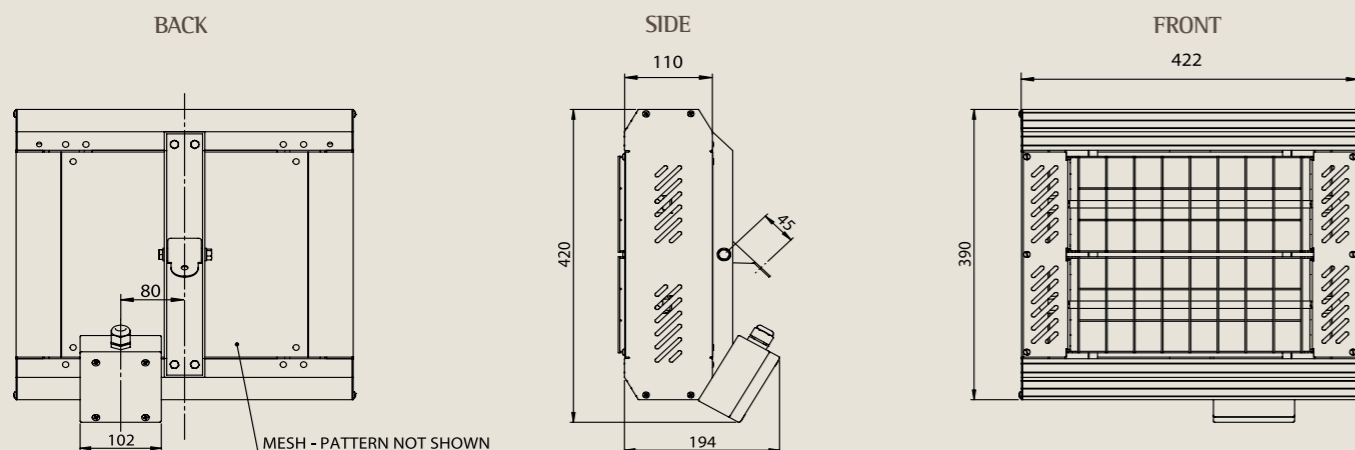

Model	Voltage (V)	Lamps x power (kW)	Total power (kW)	Phase supply (V)	Current per phase (A)	Minimum height from floor	Minimum distance from ceiling	Minimum distance from side wall	Body dimensions (W x H x D) (mm)	Weight without guard
A1B2 20IP	230	2 x 1.0	2.0	1	8.7	2.0m	0.5m	1.5m	422 x 390 x 110	4.0kg
A1B2 30IP	230	2 x 1.5	3.0	1	13.0	2.0m	0.5m	1.5m	422 x 390 x 110	4.0kg
A1B2 40IP	230	2 x 2.0	4.0	1	17.4	2.5m	0.5m	1.5m	422 x 390 x 110	4.0kg

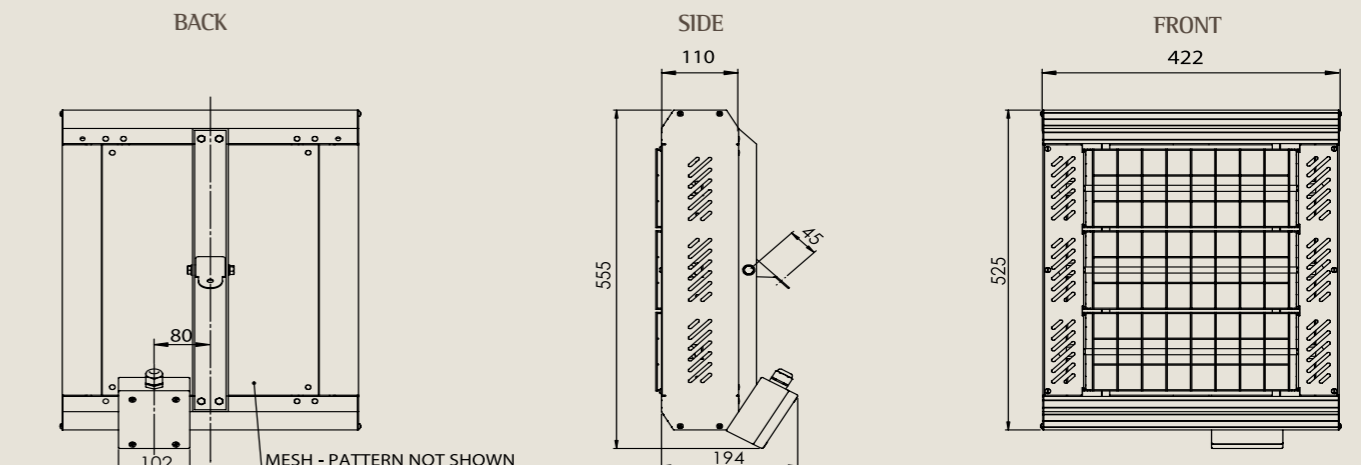

Model	Voltage (V)	Lamps x power (kW)	Total power (kW)	Phase supply (V)	Current per phase (A)	Minimum height from floor	Minimum distance from ceiling	Minimum distance from side wall	Body dimensions (W x H x D) (mm)	Weight without guard
A1C2 30IP	230	3 x 1.0	3.0	1	13.0	2.0m	0.5m	1.5m	422 x 525 x 110	5.0kg
A1C2 45IP	230	3 x 1.5	4.5	1	19.6	2.5m	0.5m	1.5m	422 x 525 x 110	5.0kg
A1C2 60IP	230	3 x 2.0	6.0	1	26.0	3.0m	0.5m	1.5m	422 x 525 x 110	5.0kg

TANSUN APOLLO A1J2 - 20IP/30IP/40IP



Apollo mounted at 3.0m from floor

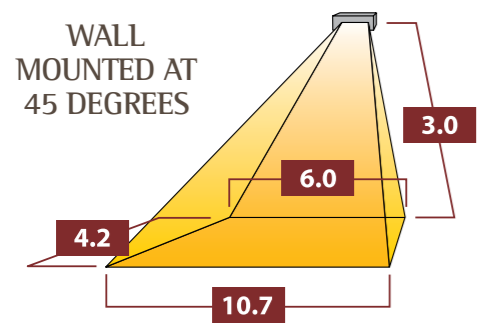

Coverage area = 35.3m sq.

CEILING MOUNTED

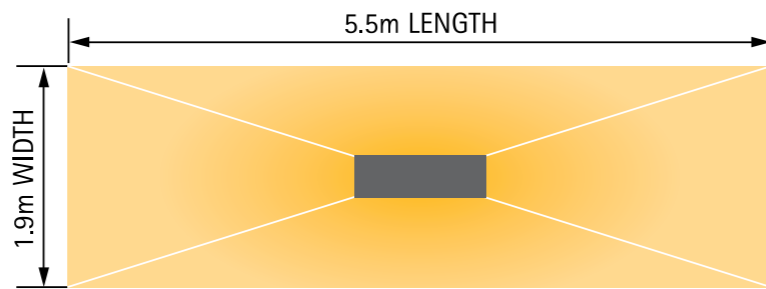

Height = 3.0m. Coverage Area = 10.5m sq.

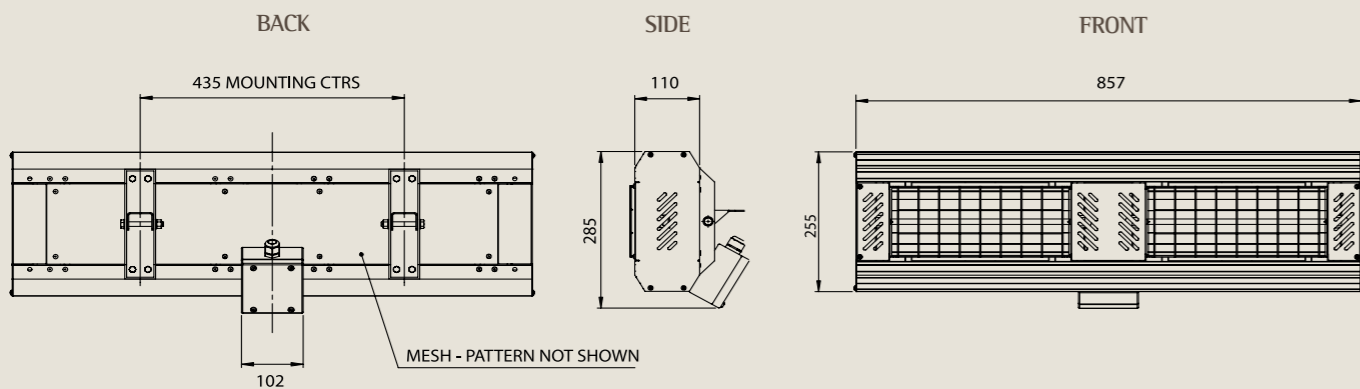

Model	Voltage (V)	Lamps x power (kW)	Total power (kW)	Phase supply (V)	Current per phase (A)	Minimum height from floor	Minimum distance from ceiling	Minimum distance from side wall	Body dimensions (W x H x D) (mm)	Weight without guard
A1J2 20IP	230	2 x 1.0	2.0	1	8.7	2.5m	0.15m	1.0m	857 x 255 x 110	6.0kg
A1J2 30IP	230	2 x 1.5	3.0	1	13.0	2.5m	0.15m	1.0m	857 x 255 x 110	6.0kg
A1J2 40IP	230	2 x 2.0	4.0	1	17.4	2.5m	0.15m	1.0m	857 x 255 x 110	6.0kg

TANSUN APOLLO A1K2 - 30IP/45IP/60IP



Apollo mounted at 3.5m from floor

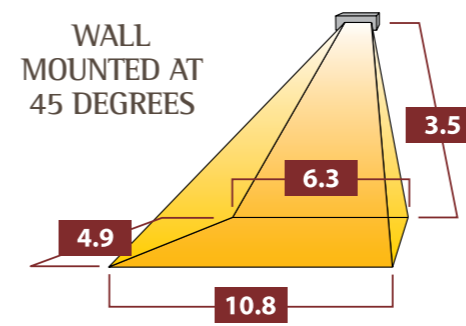

Coverage area = 41.6m sq.

CEILING MOUNTED

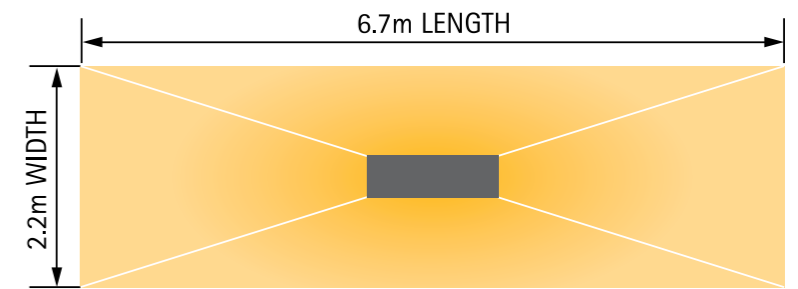

Height = 3.5m. Coverage Area = 14.8m sq.

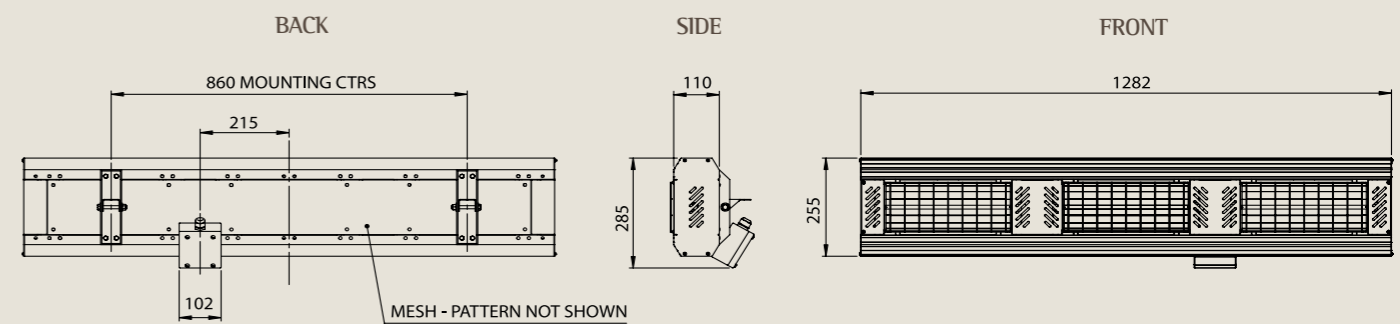

Model	Voltage (V)	Lamps x power (kW)	Total power (kW)	Phase supply (V)	Current per phase (A)	Minimum height from floor	Minimum distance from ceiling	Minimum distance from side wall	Body dimensions (W x H x D) (mm)	Weight without guard
A1K2 30IP	230	3 x 1.0	3.0	1	13.0	2.5m	0.15m	1.5m	1282 x 255 x 110	8.0kg
A1K2 45IP	230	3 x 1.5	4.5	1	19.6	2.5m	0.15m	1.5m	1282 x 255 x 110	8.0kg
A1K2 60IP	230	3 x 2.0	6.0	1	26.0	3.0m	0.15m	1.5m	1282 x 255 x 110	8.0kg

TANSUN APOLLO A3C2 - 30IP/45IP/60IP

Three Phase



Apollo mounted at 3.5m from floor

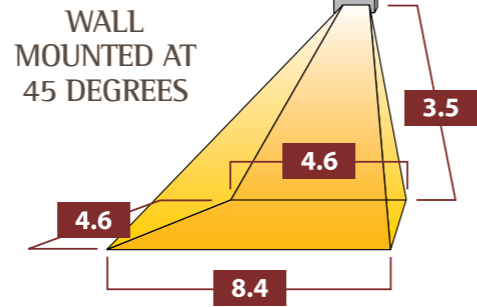

Coverage area = 30.0m sq.

CEILING MOUNTED

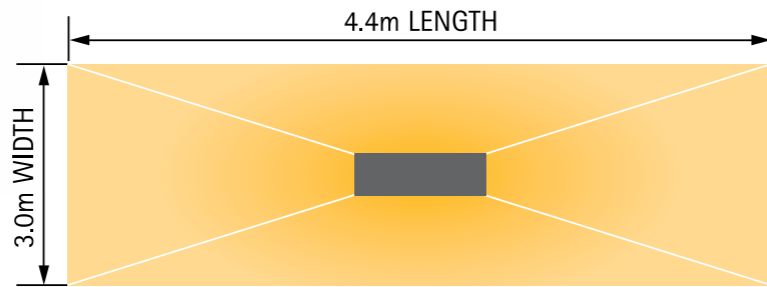

Height = 3.5m. Coverage Area = 13.4m sq.

TANSUN APOLLO A3E2 - 60I0IP/120IP

Three Phase



Apollo mounted at 5.0m from floor

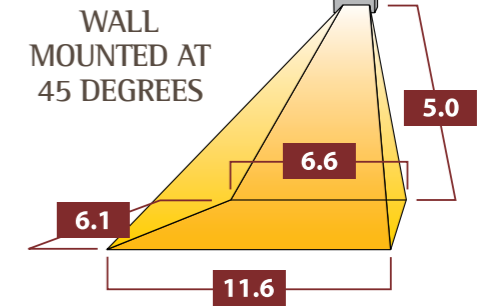

Coverage area = 55.1m sq.

CEILING MOUNTED

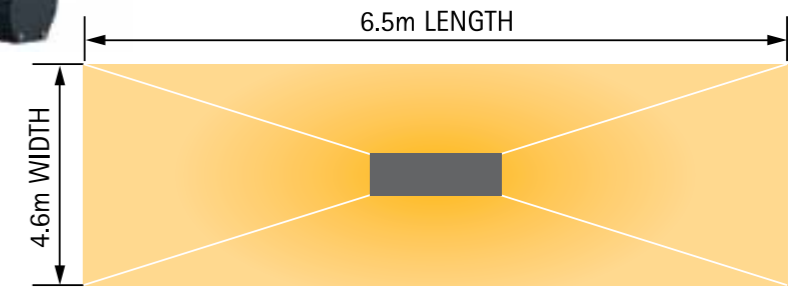

Height = 5.0m. Coverage Area = 29.8m sq.

BACK

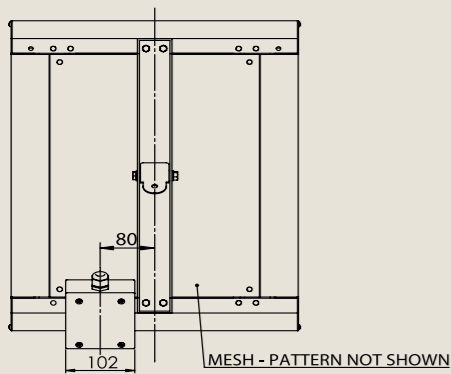

MESH - PATTERN NOT SHOWN

SIDE

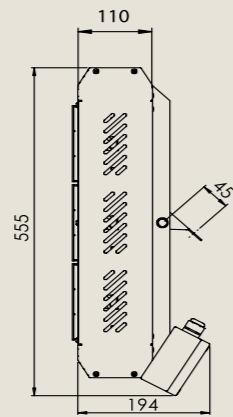

FRONT

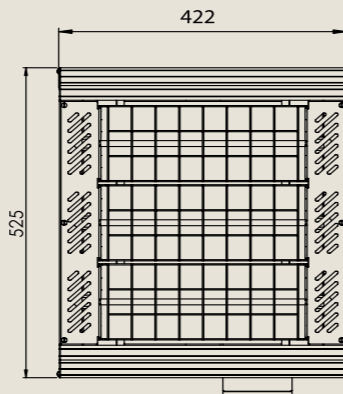

Model	Voltage (V)	Lamps x power (kW)	Total power (kW)	Phase supply (V)	Current per phase (A)	Minimum height from floor	Minimum distance from ceiling	Minimum distance from side wall	Body dimensions (W x H x D) (mm)	Weight without guard
A3C2 30IP	400	3 x 1.0	3.0	3*	4.3	2.0m	0.5m	1.5m	422 x 525 x 110	5.5kg
A3C2 45IP	400	3 x 1.5	4.5	3*	6.5	2.5m	0.5m	1.5m	422 x 525 x 110	5.5kg
A3C2 60IP	400	3 x 2.0	6.0	3*	8.7	3.0m	0.5m	1.5m	422 x 525 x 110	5.5kg

BACK

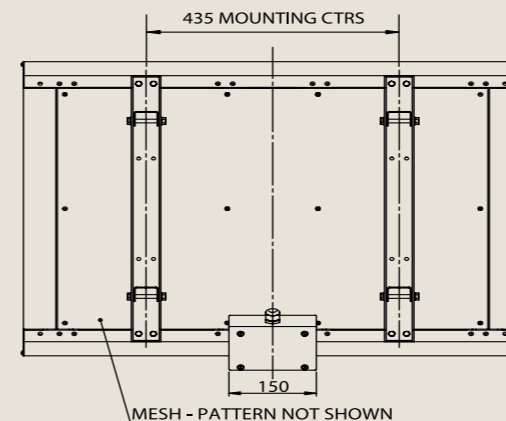

MESH - PATTERN NOT SHOWN

SIDE

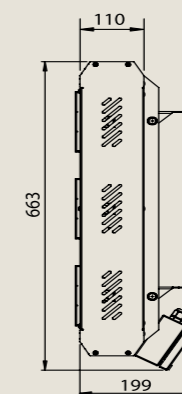

FRONT

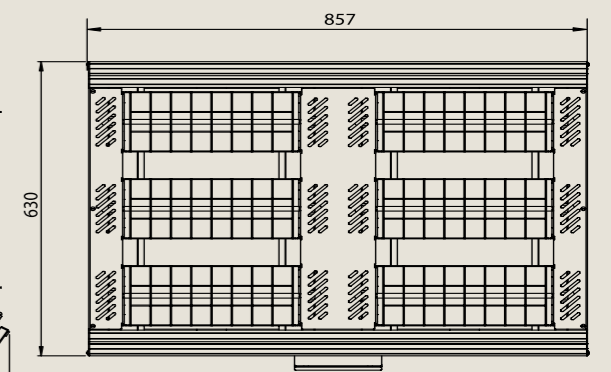

Model	Voltage (V)	Lamps x power (kW)	Total power (kW)	Phase supply (V)	Current per phase (A)	Minimum height from floor	Minimum distance from ceiling	Minimum distance from side wall	Body dimensions (W x H x D) (mm)	Weight without guard
A3E2 60IP	400	6 x 1.0	6.0	3*	8.7	3.0m	0.5m	1.5m	857 x 630 x 110	12.0kg
A3E2 90IP	400	6 x 1.5	9.0	3*	13.0	4.0m	0.5m	1.5m	857 x 630 x 110	12.0kg
A3E2 120IP	400	6 x 2.0	12.0	3*	17.4	4.5m	0.5m	1.5m	857 x 630 x 110	12.0kg

TANSUN APOLLO A3F2 - 90IP/135IP/180IP

Three Phase

9.0/18 kW 20.0 Kg IP RAL Standard Colour



Apollo mounted at 6.0m from floor

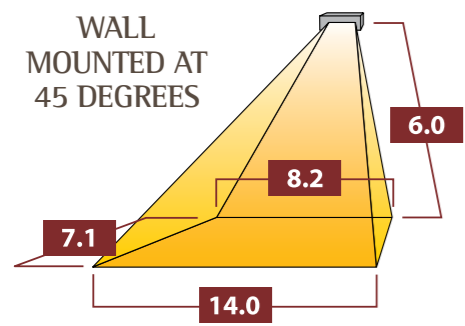

Coverage area = 79.0m sq.

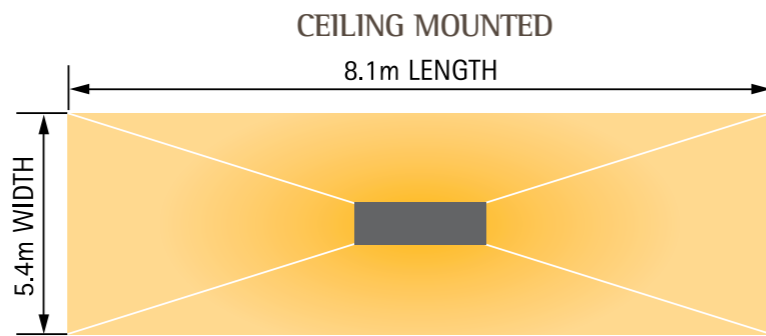

Height = 6.0m. Coverage Area = 43.6m sq.

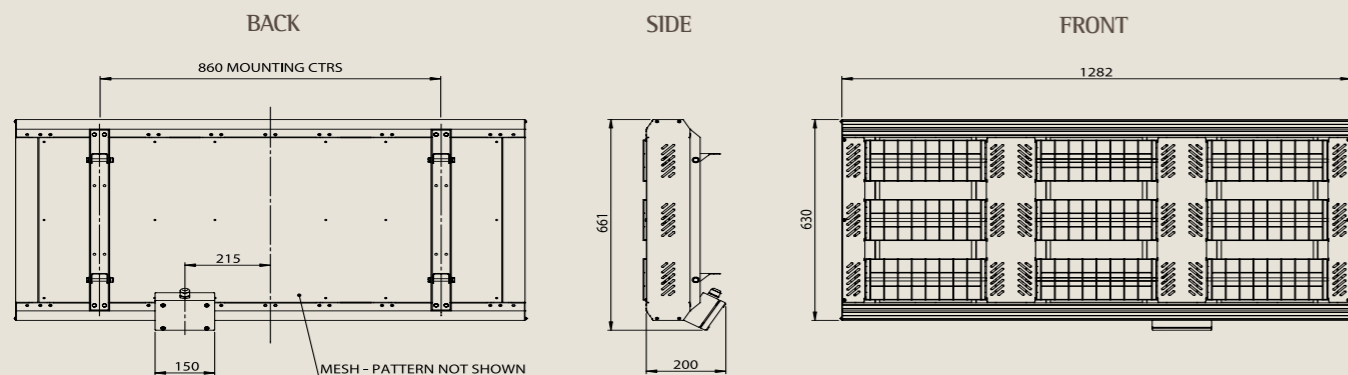

Model	Voltage (V)	Lamps x power (kW)	Total power (kW)	Phase supply (V)	Current per phase (A)	Minimum height from floor	Minimum distance from ceiling	Minimum distance from side wall	Body dimensions (W x H x D) (mm)	Weight without guard
A3F2 90IP	400	9 x 1.0	9.0	3*	13.0	4.0m	0.5m	1.5m	1282 x 630 x 110	20.0kg
A3F2 135IP	400	9 x 1.5	13.5	3*	19.6	5.0m	0.5m	1.5m	1282 x 630 x 110	20.0kg
A3F2 180IP	400	9 x 2.0	18.0	3*	26.1	6.0m	0.5m	1.5m	1282 x 630 x 110	20.0kg

TANSUN APOLLO A3K2 - 30IP/45IP/60IP

Three Phase

3.0/6 kW 8.0 Kg IP RAL Standard Colour



Apollo mounted at 3.5m from floor

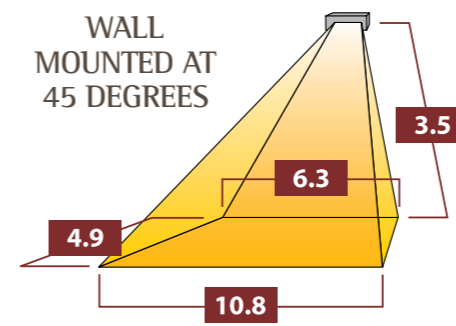

Coverage area = 41.6m sq.

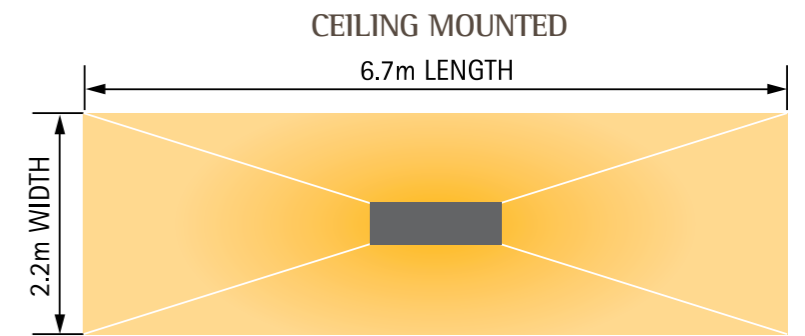

Height = 3.5m. Coverage Area = 14.8m sq.

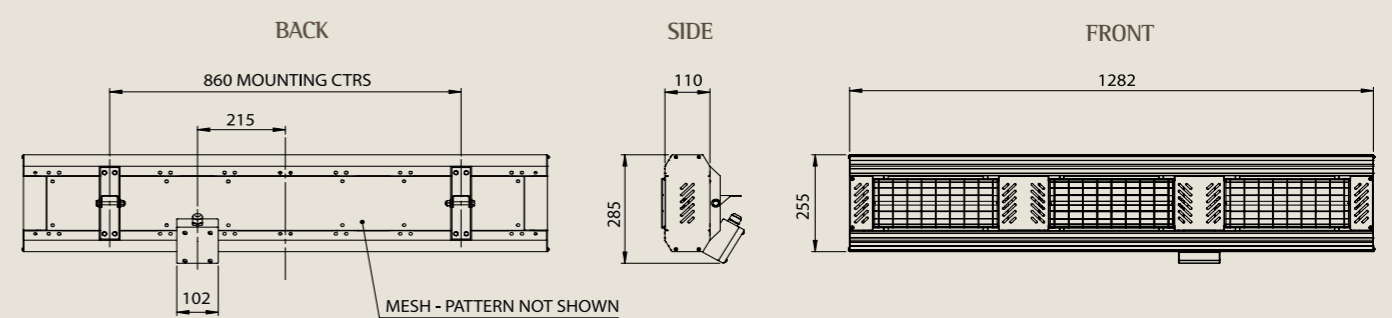

Model	Voltage (V)	Lamps x power (kW)	Total power (kW)	Phase supply (V)	Current per phase (A)	Minimum height from floor	Minimum distance from ceiling	Minimum distance from side wall	Body dimensions (W x H x D) (mm)	Weight without guard
A3K2 30IP	400	3 x 1.0	3.0	3*	4.3	2.5m	0.5m	1.5m	1282 x 255 x 110	8.0kg
A3K2 45IP	400	3 x 1.5	4.5	3*	6.5	2.5m	0.5m	1.5m	1282 x 255 x 110	8.0kg
A3K2 60IP	400	3 x 2.0	6.0	3*	8.7	3.0m	0.5m	1.5m	1282 x 255 x 110	8.0kg

TANSUN APOLLO A3L2 - 60IP/90IP/120IP

Three Phase



Apollo mounted at 4.5m from floor

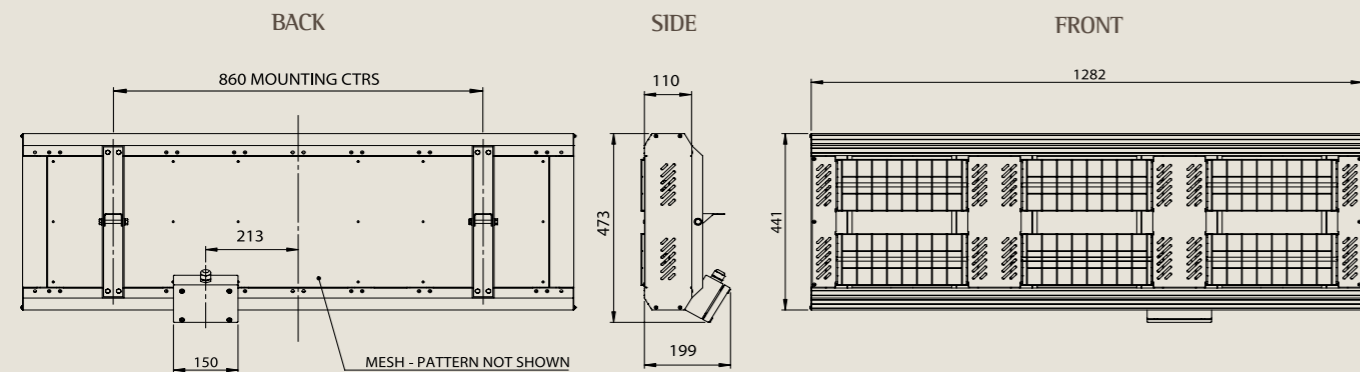
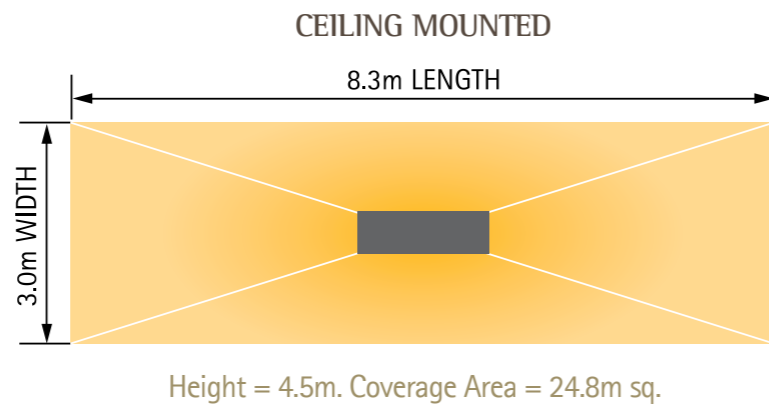
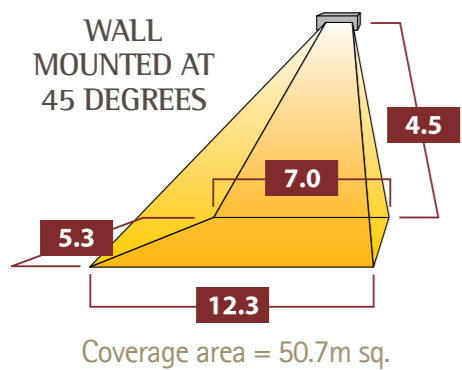

Model	Voltage (V)	Lamps x power (kW)	Total power (kW)	Phase supply (V)	Current per phase (A)	Minimum height from floor	Minimum distance from ceiling	Minimum distance from side wall	Body dimensions (W x H x D) (mm)	Weight without guard
A3L2 60IP	400	6 x 1.0	6.0	3*	8.7	3.0m	0.5m	1.5m	1282 x 441 x 110	17.0kg
A3L2 90IP	400	6 x 1.5	9.0	3*	13.0	4.0m	0.5m	1.5m	1282 x 441 x 110	17.0kg
A3L2 120IP	400	6 x 2.0	12.0	3*	17.4	4.5m	0.5m	1.5m	1282 x 441 x 110	17.0kg

APOLLO MOUNTING OPTIONS:

Installing the Apollo is often much simpler than most other forms of heating such as gas alternatives with no pipework etc. to have to consider. The Apollo can be mounted in various ways including ceiling hung from chains, mounted on the wall at various angles, and recessed in ceilings. We can assist further with the best mounting options for various schemes in our free heating design service.

APOLLO A CHAIN HUNG
FACE DOWN



APOLLO E CHAIN HUNG
45 DEGREES



APOLLO A IN A RECESS CLOSE UP

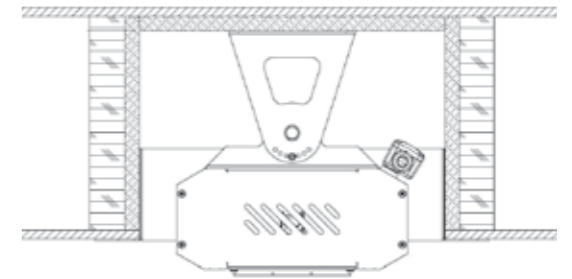

APOLLO A CHAINS
HUNG 45 DEGREES

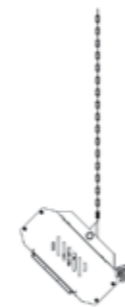

CEILING MOUNT
CLOSE UP

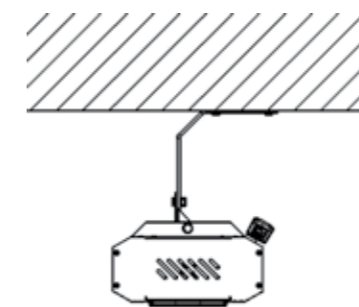

APOLLO RECESSED

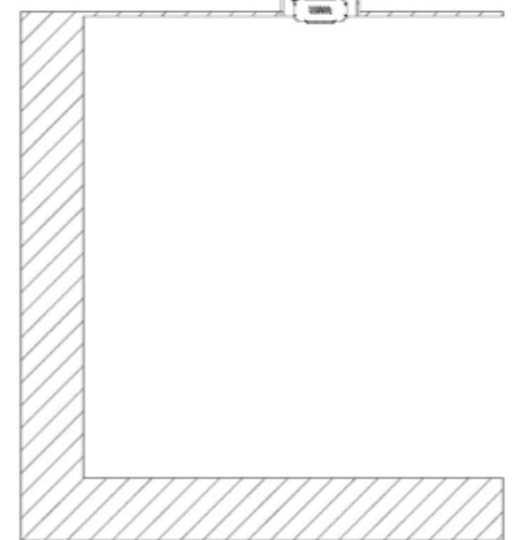

APOLLO J WALL MOUNT

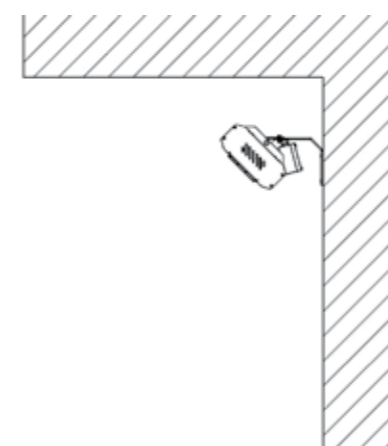

APOLLO A CEILING MOUNT FACE DOWN

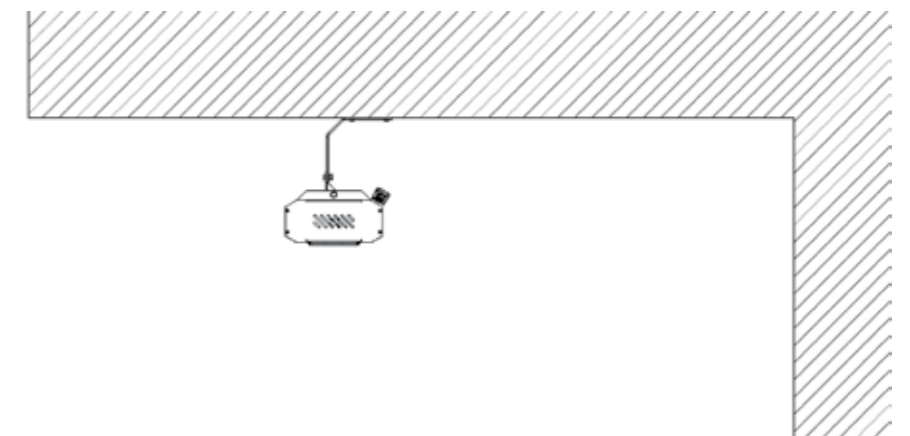



Tansun Ltd
Spectrum House
Ridgacre Road
West Bromwich
West Midlands
B71 1BW

Tel: +44 (0)121 580 6200
Fax: +44 (0)121 580 6222

Website: www.tansun.com
Email: sales@tansun.com

Copyright 2018 © Tansun Ltd. All rights reserved

Tansun heaters are designed and manufactured for outdoor use. They can be used indoors but should be used in conjunction with suitable energy saving controllers. Please contact Tansun for controllers for these applications.

Technical data subject to change without prior notice

Part number: 043147 Revision: 2

